

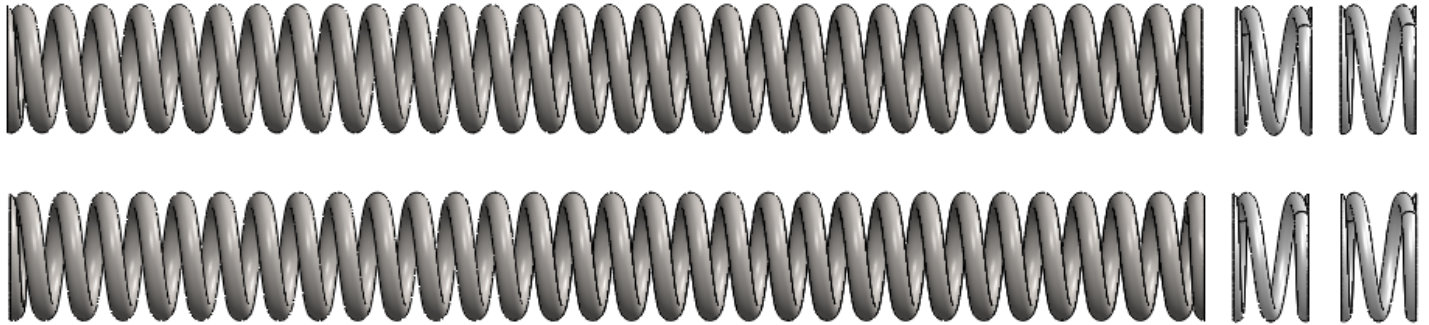

INSTALLATION INSTRUCTIONS

FORK LOWERING SPRING KIT FOR 2018 & LATER* SOFTAIL
MODELS WITH CONVENTIONAL FORKS



ATTENTION!

Statements in these instructions that are preceded by the following symbols are of special significance:



This symbol means there is the possibility of injury to yourself or others.



This symbol means there is the possibility of damage to the vehicle.

NOTE:

Information of particular importance has been placed in italics.

LIFETIME LIMITED WARRANTY

Progressive Suspension warrants to the original purchaser this part to be free of manufacturing defects in materials and workmanship with a lifetime limited warranty. In the event warranty service is required, you must call Progressive Suspension immediately with a description of the problem.

If it is deemed necessary for Progressive Suspension to make an evaluation to determine whether the part is defective, a return authorization number will be given by Progressive Suspension. The parts must be packaged properly so as to not cause further damage and returned prepaid to Progressive Suspension with a copy of the original invoice of purchase and a detailed letter outlining the nature of the problem. If after the evaluation by Progressive Suspension the part was found to be defective it will be repaired or replaced at no cost to you. If we replace it, we may replace it with a reconditioned one of the same design.

Progressive Suspension shall not be held liable for any consequential or incidental damages resulting from the failure of a Progressive Suspension part. Progressive Suspension shall have no obligation if a part becomes defective as a result of improper installation or abuse.

IMPORTANT NOTICE

Removing and replacing fork springs must be performed by a qualified mechanic & according to steps outlined in a professional workshop manual that relates to your particular make, model & year motorcycle.

The vehicle must be securely blocked to prevent it from dropping or tipping when the forks/fork springs are removed. Failure to do so can cause serious damage and/or injury.

Progressive Suspension Fork Springs are designed to work with the OEM (Original Equipment) forks. Use of this product on any forks other than OEM may produce an unsatisfactory ride & void the warranty.

RECOMMENDED TOOLS

FOL-2 PROGRESSIVE SUSPENSION FORK LEVEL ADJUSTER
HYDRAULIC PRESS

*HD-41177 FORK TUBE HOLDER or EQUIVALENT

(*HD PART NUMBERS SHOWN ARE FOR HARLEY-DAVIDSON FACTORY TOOLS)



TECH: 714.523.8700

13861 ROSECRANS AVE, SANTA FE SPRINGS, CA 90670

FAX: 714.523.3220



FORK LOWERING SPRING KIT FOR 2018 & LATER* SOFTAIL MODELS WITH CONVENTIONAL FORKS



LOWERING THE CHASSIS AND/OR SUSPENSION ON ANY VEHICLE WILL CHANGE THE HANDLING CHARACTERISTICS AND LEAN ANGLE OF THAT VEHICLE. CARE SHOULD BE TAKEN WHEN OPERATING THE VEHICLE WITH SUCH MODIFICATIONS WHILE GETTING ACCUSTOMED TO THE NEW HANDLING CHARACTERISTICS.



WHILE THE INSTALLATION OF THIS KIT WILL NOT CHANGE THE COMPRESSED LENGTH OF THE FRONT FORKS, WE HAVE FOUND THAT SOME BIKES MAY NOT HAVE ADEQUATE CLEARANCE BETWEEN THE FENDER, FAIRING AND / OR ACCESSORIES. SO WE RECOMMEND WITH THE FORK SPRINGS REMOVED FROM BOTH FORKS, REINSTALL THE FORKS, FENDER, WHEEL AND ANYTHING ELSE YOU MAY HAVE REMOVED AND LIFT THE FRONT FORKS, OR LOWER THE BIKE TO FULLY COMPRESS THE FRONT FORKS. TURN THE HANDLEBARS BACK AND FORTH, LOCK TO LOCK WHILE CHECKING FOR ADEQUATE CLEARANCE BETWEEN THE TIRE, FENDER, FAIRING, CRASH BAR, ACCESSORIES ETC. YOU MUST CORRECT ANY CLEARANCE ISSUES PRIOR TO INSTALLING THIS KIT TO AVOID VEHICLE CONTROL PROBLEMS AND / OR DAMAGE.

INSTALLATION

Read all the instructions carefully before installing this kit on your motorcycle. Use your factory authorized service manual as a reference while installing this kit.

NOTE:

This kit provides for either a 1" or 2" lower front ride height - pay close attention to the following steps that pertain to your preferred ride height configuration.

1. Support and lift the motorcycle securely so the front wheel is off the ground. The balance point is toward the front of the engine.



THE FORK CAPS ARE UNDER EXTREME SPRING PRESSURE. CARE MUST BE TAKEN AS THEY ARE REMOVED TO AVOID INJURY. KEEP DOWNWARD PRESSURE ON THE CAPS AS YOU UNSCREW THE FINAL THREADS TO MINIMIZE THE SPRING "JUMP" THAT WILL OCCUR AS SOON AS THE CAPS ARE FULLY UN-THREADED. USE A SPRING COMPRESSOR OR HYDRAULIC PRESS AS OUTLINED BELOW FOR THIS PURPOSE. IF YOU ARE UNCERTAIN IN ANY WAY ABOUT THIS PORTION OF THE PROCEDURE - STOP HERE AND TAKE YOUR FORKS TO A COMPETENT MECHANIC TO INSTALL THIS KIT.

2. Remove the forks from the bike
3. Loosen the fork cap one full turn
4. Position and secure fork assembly in press so it can be compressed slightly and the inner fork-tube can be freely rotated – also be sure that the press ram can move upward from that position 3.00" to 4.00" inches to allow the spring to extend once the cap is removed.



THE FORK ASSEMBLY MUST BE HELD IN ALIGNMENT WITH THE PRESS RAM AT ALL TIMES TO ENSURE SAFE SPRING EXPANSION/COMPRESSION WHEN THE FORK CAP IS UN-THREADED FROM THE FORK TUBE.

5. Compress the fork about .50" to 1.00" (Figure 1)
6. Now, with the press holding the spring pressure, you should be able to unscrew the fork tube from the fork cap by hand (Figure 2)





FORK LOWERING SPRING KIT FOR 2018 & LATER* SOFTAIL MODELS WITH CONVENTIONAL FORKS

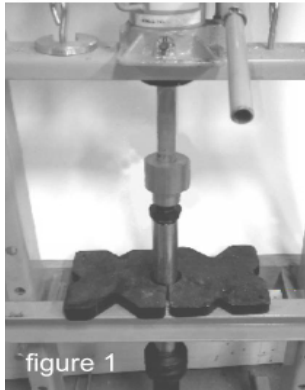

7. Once the fork tube is completely un-threaded from the cap (Figure 3) carefully release the press, allowing the fork spring to safely extend fully (Figure 4) For assembly, simply reverse the preceding steps.

NOTE:

For maximum performance we highly recommend that the forks be disassembled and thoroughly cleaned, inspected and new Progressive Suspension Standard (Type E) fork oil installed.

8. Drain the fork oil, then with the fork completely compressed, remove the damper rod and OE top out spring by removing the fork bolt (with sealing washer) in the bottom of the fork. Keep the fork fully compressed at this point to keep the OE bottoming cup properly located.
9. In addition to the OE top out spring (on the damper rod) install either **ONE** or the supplied top out springs to lower your fork approximately 1" **OR TWO** of the supplied top out springs to lower your fork approximately 2". **See illustration on page 4.**
10. Drop the damper rod along with the chosen number of top out springs back into the fork. Put a drop of thread locking agent on the fork bolt that came out of the bottom of the fork and reinstall it (with sealing washer). Tightening it back into the damper rod and torque (30-37 ft lbs)
11. Repeat this process on the other fork - putting the same number of top out springs on the damper rod.
12. Secure the fork assembly and fill with it with fork oil. We recommend Progressive Suspension Standard 10wt (Type E) fork oil. Fully cycle the forks several times to purge air as you add oil. Fill to the proper fork oil level as indicated in the next step.
13. Before installing the supplied main springs, it is crucial that you make sure you've installed the proper fork oil and the oil level is correct. To check the oil level properly you must have the main springs and spacers removed, cycle the forks several times to purge any trapped air and then completely compress the forks. You then measure from the top of the fork tube to the oil level. Add/remove oil to achieve measurements. **For 1" low configuration (BOTH FORKS- 155mm)**
For 2" low configuration (BOTH FORKS- 145mm)



NEVER ADD TOO MUCH OIL RESULTING IN A MEASUREMENT LESS THAN 155MM IN EACH FORK WITH A 1" LOW CONFIGURATION OR 145MM IN EACH FORK WITH A 2" LOW CONFIGURATION WHEN USING THIS SPRING KIT!





FORK LOWERING SPRING KIT FOR 2018 & LATER* SOFTAIL MODELS WITH CONVENTIONAL FORKS

- After confirming the fork oil level for your chosen configuration, install a Progressive Suspension main spring into the fork, followed by the OE washer. **Referring to the included application supplement for recommended spacer length for your chosen configuration**, install the included spacer (cut to the length indicated for your chosen configuration). Reinstall the fork cap. (Refer to steps 7 back through 4)
- Torque the fork caps (22-30 ft lbs) and reinstall the forks and any other components previously removed per a factory authorized service manual. Remove motorcycle from lift and recheck all fasteners for proper tightness per your factory authorized manual.

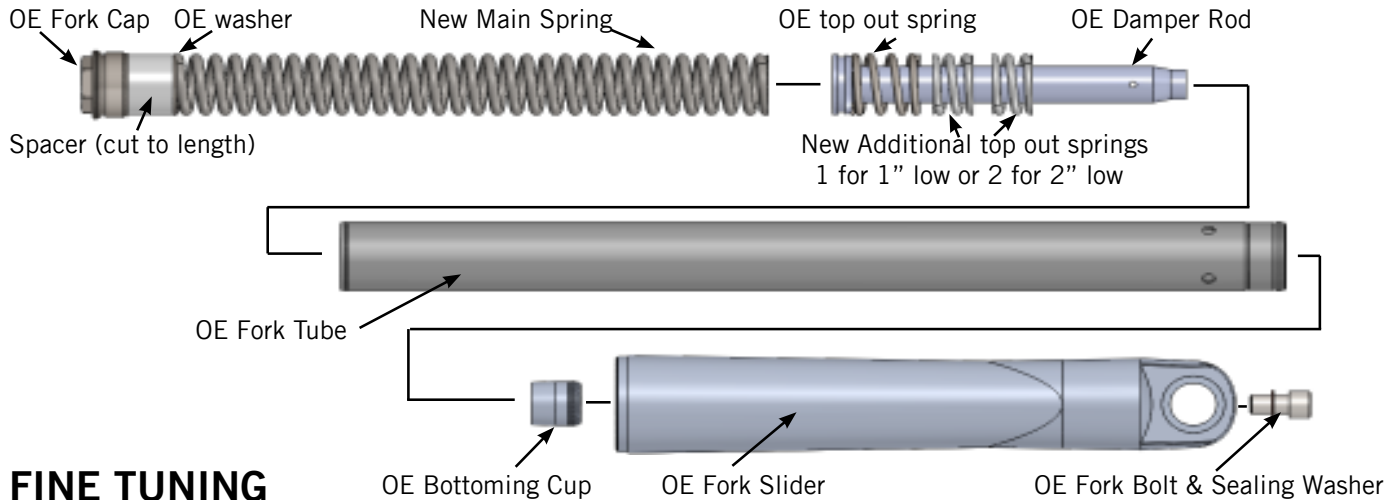

FINE TUNING

FORK OIL: Though we recommend using Type E (10wt) fork oil, oil viscosity can be changed to alter damping. Heavier oil to increase damping. Lighter oil to decrease damping. Change in 5 weight increments (i.e. from 10wt to 15wt). Oil viscosity will have more effect on rebound damping than compression damping, too high a viscosity can create harshness on sharp edge bumps. The oil level also affects the ride, too high an oil level and the forks will feel too stiff, too low an oil level and the bike will bottom and feel soft or dive excessively. As stated previously, when using this spring kit **NEVER adjust the fork oil level to produce a measurement of less than 155mm in each fork with a 1" low configuration or less than 145mm in each fork with a 2" low configuration - measured with fork springs & spacers removed, forks compressed, from the top of the fork tube - or damage will occur.**

SPACER LENGTH: Spacer length may also be altered from the length recommended as a way to fine tune your front ride height. However, using a spacer length that is shorter than the recommended length for a 2" low configuration may promote bottoming.



NEVER USE SPACERS LONGER THAN 4.0" WITH THIS KIT OR DAMAGE WILL OCCUR

TECHNICAL INFO

Our technical staff will assist you if you have any problems or questions. Call (714) 523-8700 from 8am to 4pm PST.



TECH: 714.523.8700

13861 ROSECRANS AVE, SANTA FE SPRINGS, CA 90670

FAX: 714.523.3220