



18/418 Series Aluminum Body One-Way Adaptive Installation Instructions

Note: Please read all instructions thoroughly before starting installation.

Note: These shocks are designed to operate with the shock shaft UP. Damage to the shocks may occur if fitted shock shaft down.

Note: 18 Series are sold with springs not installed. 418 are sold with springs installed.

Caution: Follow instructions in an authorized shop manual or take the motorcycle to a dealer or repair shop. The motorcycle must be on a centerstand (if equipped) or securely blocked to prevent it from tipping over when the shocks are removed.

1. Place the motorcycle on the centerstand or block the motorcycle securely so the rear wheel is slightly off the ground.
2. Remove the old shocks and note location of mounting hardware. If additional accessories are installed on your motorcycle, please refer to their mounting instructions for removal to gain access to the shocks.

Note: Steps (3-5) are only necessary if aftermarket fender, tire or any other accessories have been installed. If none of these applies, 18 Series proceed to step 5, 418 Series proceed to step 6.

Caution: Make sure that the proper bushings/sleeves are installed in the shocks. Improper bushings/sleeves can cause unsatisfactory or unsafe operation.

Bushings: A universal hardware kit is included. Determine the proper sleeves and washers for mounting stud/bolt for your particular application. Not all parts will be used.

3. Install one shock (without spring) and check clearance (#A in Fig. 1). Raise wheel into fender well until shock bottoms. There should be a minimum of 1" of clearance between the tire and fender.

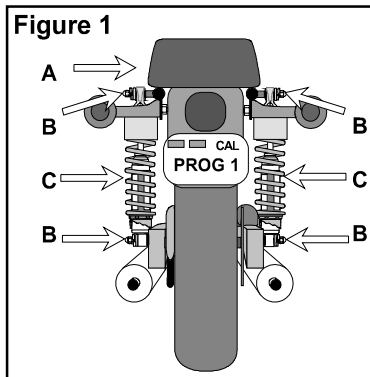

4. If clearance (#A) is sufficient, remove the shock and install the springs onto the shock (See Step 5).

Caution: This step requires a spring compression tool from Progressive Suspension, (Part #32-5503). If a spring compression tool is not available, refer the work to your local dealer or repair shop. Attempting to compress the springs without the proper tool may result in serious injury or damage to the shock!

5. Spring Installation:

A. Install tab cover and cam adjuster to the minimum setting (lowest point on preload ramps). See A figure 2.

B. Install plastic body protector insuring that the protrusion seats into the cam adjuster. See B figure 2.

C. Install the spring.

D. Install retaining ring above the spring. Make sure the circlip bevel is facing upward. Place the wire circlip over the top eye sliding it close to the retaining ring. See C figure 2.

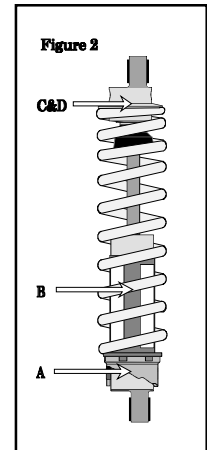

E. Using a spring compressor tool, compress the spring enough to install wire circlip in the groove. Slide the wire circlip down into the groove. Release the spring slowly, making sure the spring retainer ring seats fully on the wire circlip. See D figure 2.

6. Install assembled shock absorbers onto motorcycle and tighten mounting nuts/bolts to proper torque specifications (consult your service manual for correct specifications). Now check clearances (B & C) in figure 1.
- (B) Shock to frame at mounting points.
 - (C) Shock to chain/chain guide, disc caliper and linkage. Also check clearance to any accessories.

Note: The shock mounts are offset to allow clearance between the shocks and the motorcycle. Install the shocks with offset towards the motorcycle (see figure 3).

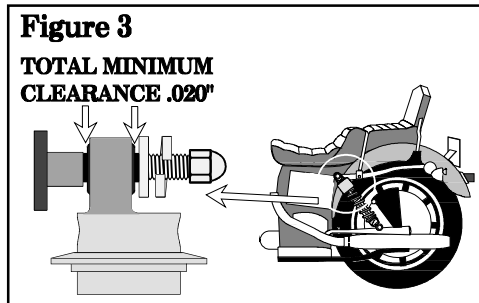

7. Reinstall any accessories removed according to their mounting instructions. Make sure accessories do not interfere with shocks throughout full travel. If any accessories bolt to the shock mounting points, a careful check must be made to insure that they do not bind the shocks in any way (See Figure 3).
8. 418 Series Shocks have four positions to adjust the spring preload. (They are in the lightest position from the factory.) Always adjust preload equally on both shocks and make sure the rebound adjustments are both at the same settings. (See rebound adjustment below!).
- A. For easier spring preload adjustments, put a small amount of cam adjuster lube (supplied) on the sliding surface prior to rotating the cam.

9. Test Ride:

- A. If excessive bottoming occurs, rotate cam adjuster to a higher setting on both shocks. (See Step 4) If bottoming persists after adjusting to the highest setting, a spring with a higher rate may be required.
- B. If excessive topping occurs with the cam adjuster in the lightest position a higher rebound damping number or a spring with a lighter rate may be required.

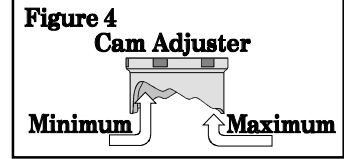

C. Adjusting rebound damping:

Too little rebound damping can cause wallowing in turns, a "springy" feel under acceleration out of the turns and a tendency to push the rider forward on the machine while going over big bumps and depressions.

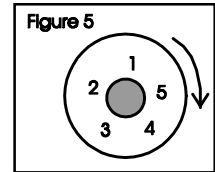

Too much rebound damping causes a harsh ride, wheel chatter on breaking and tendency for the machine to stay squatted after hitting a bump (packing down).

Rebound Adjustment: Adjust rebound damping using the 1/4" allen wrench that is enclosed with the shocks.

Position 1 is the least rebound damping force, while position 5 is the highest.

Note: The 418 Series One Way Adaptive has a hydraulic anti-topping design which slows the rebound damping dramatically towards the end of the shock travel. This damping feature helps keep the motorcycle stable as the shock returns from compression.

All damping adjustments should be tested by thoroughly riding the motorcycle.

10. Maintenance: Shock bushings should be checked and cleaned at periodic intervals. Shock oil should be changed every two years.
11. For balanced suspension, we highly recommend the installation of a pair of our progressive rate fork springs.