



6911 Marlin Circle, La Palma, CA 90623
(714) 523-8700, Fax (714) 523-3220

465 Series Single Shock Supplement for Kawasaki KLR-650 (with Remote Adjustable Pre-Load)

Please read these instructions completely before starting!

Check the spring part number on your shock - it **must** be part number 01-1003 (or 01-1005 for a 08-10 KLR650 1" lower application). The spring part number should be located on one of the coils near the clevis end of the shock, and may also include the spring rate number(s). If you do not have the proper spring, you **must** get one before installing the Remote Adjustable Pre-Load adjuster on your shock.

Shouldered sleeves with O-rings should already be installed in the shock eye. If not, insert sleeves with O-rings in the top eye (see figure 1).

Check the orientation of the adjuster on the shock body - looking at the top of the shock, it should be 20 degrees (counterclockwise) from the nitrogen pressure valve to the hydraulic line port on the adjuster (see figure 2). If it is not properly oriented, you will need to reposition it. To do this, hold the upper shock eye securely in a vice and carefully rotate the Remote Adjustable Pre-Load adjuster the desired direction. This may be somewhat difficult due to spring tension, and may require slight loosening of the locking ring. Also, the spring, shaft, and lower mount may rotate while repositioning the adjuster. This is OK, just be sure to realign it with the upper mount (also be sure the rebound adjuster on the lower mount is properly oriented as noted below).

Mount the shock as you would your stock shock per your authorized shop manual (with the rebound adjustment at the bottom) noting the following:

- As you mount the shock, feed the Remote Adjustable Pre-Load adjuster through the opening between the main-frame and sub-frame on the left side of the bike.
- Do not loosen or attempt to rotate the line between the shock and the adjuster.
- Make sure the shock rebound adjustment is facing the right side of the motorcycle and the pressure valve is facing forward.
- **On 1987-2007 models ONLY**, install the supplied 3.5mm thick spacers - one on each side of the shock clevis (see figure 3). Do not install these spacers on 2008-2010 models.
- Tighten shock bolts to the proper torque specifications (refer to your manual).
- Mount the adjuster to the supplied mounting bracket using the supplied M6-1.0X8mm SHCS fasteners and torque them to 80-90 in/lbs (9-10 N-m). Then mount the bracket to the bike using the two rear footrest mounting bolts - sandwiching the mounting bracket between the rear footrest mount and the frame tabs (as shown in figure 4). Using the supplied zip-ties, secure the hydraulic line away from any moving parts or heat sources.
- To adjust the ride height, simply turn the adjuster knob clockwise (looking at it from the back of the bike) to increase the height and counterclockwise to reduce it. See main instructions for procedure of achieving optimum ride height.

Caution: With the adjuster in the lightest/lowest setting (all the way counterclockwise) the installed spring length must never be set shorter than the following lengths, or damage will occur:

201mm (7.90") for the 465-1001 or 465-5001 (08-10 Standard)
189mm (7.43") for the 465-1002 or 465-5002 (08-10 1" LOW)
207mm (8.16") for the 465-1130 or 465-5003 (87-07 Standard)
197mm (7.75") for the 465-1144 or 465-5006 (87-07 1" LOW)

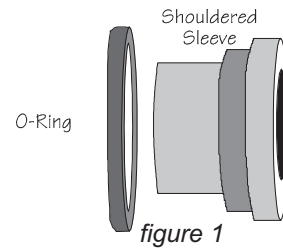

figure 1

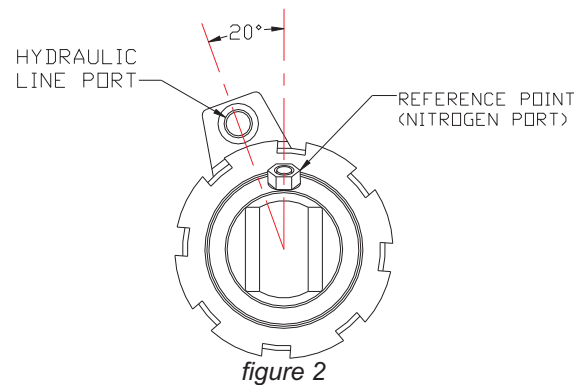

figure 2

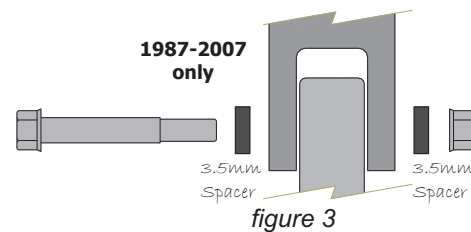

figure 3



figure 4